



# NEPAL NATIONAL BUILDING CODE

NBC 205 : 1994



## MANDATORY RULES OF THUMB REINFORCED CONCRETE BUILDINGS WITHOUT MASONRY INFILL

**Government of Nepal**  
**Ministry of Physical Planning and Works**  
Department of Urban Development and Building Construction  
**Babar Mahal, Kathmandu, NEPAL**  
Reprinted : 2064



# NEPAL NATIONAL BUILDING CODE

NBC 205 : 1994



## MANDATORY RULES OF THUMB REINFORCED CONCRETE BUILDINGS WITHOUT MASONRY INFILL

**This publication represents a standard of good practice and therefore takes the form of recommendations. Compliance with it does not confer immunity from relevant legal requirements, including bylaws.**

तत्कालिन श्री ५ को सरकार (मन्त्रिपरिषद्) को मिति २०६०।४।१२ को निर्णयानुसार स्वीकृत

**Government of Nepal**  
**Ministry of Physical Planning and Works**  
Department of Urban Development and Building Construction  
**Babar Mahal, Kathmandu, NEPAL**  
Reprinted : 2064

## **Preface**

This Nepal Standard was prepared during 1993 as part of a project to prepare a National Building Code for Nepal.

In 1988 the Ministry of Housing and Physical Planning (MHPP), conscious of the growing needs of Nepal's urban and shelter sectors, requested technical assistance from the United Nations Development Programme and their executing agency, United Nations Centre for Human Settlements (UNCHS).

A programme of Policy and Technical Support was set up within the Ministry (UNDP Project NEP/88/054) and a number of activities have been undertaken within this framework.

The 1988 earthquake in Nepal, and the resulting deaths and damage to both housing and schools, again drew attention to the need for changes and improvement in current building construction and design methods.

Until now, Nepal has not had any regulations or documents of its own setting out either requirements or good practice for achieving satisfactory strength in buildings.

In late 1991 the MHPP and UNCHS requested proposals for the development of such regulations and documents from international organisations in response to terms of reference prepared by a panel of experts.

This document has been prepared by the subcontractor's team working within the Department of Building, the team including members of the Department and the MHPP. As part of the proposed management and implementation strategy, it has been prepared so as to conform with the general presentation requirements of the Nepal Bureau of Standards and Metrology.

The subproject has been undertaken under the aegis of an Advisory Panel to the MHPP.

The Advisory Panel consisted of :

<b>Mr. UB Malla, Joint Secretary, MHPP</b>	<b>Chairman</b>
<b>Director General, Department of Building</b>	
<b>(Mr. LR Upadhyay)</b>	<b>Member</b>
<b>Mr. AR Pant, Under Secretary, MHPP</b>	<b>Member</b>
<b>Director General, Department of Mines &amp; Geology</b>	
<b>(Mr. PL Shrestha)</b>	<b>Member</b>
<b>Director General, Nepal Bureau of Standards &amp; Metrology</b>	
<b>(Mr. PB Manandhar)</b>	
<b>Member</b>	
<b>Dean, Institute of Engineering, Tribhuvan University</b>	
<b>(Dr. SB Mathe)</b>	<b>Member</b>
<b>Project Chief, Earthquake Areas Rehabilitation &amp; Reconstruction Project</b>	
<b>Member</b>	
<b>President, Nepal Engineers Association</b>	<b>Member</b>

**Law Officer, MHPP (Mr. RB Dange)**

**Member**

**Representative, Society of Consulting Architectural &  
Engineering Firms (SCAEF)**

**Member**

**Representative, Society of Nepalese Architects (SONA)**

**Member**

**Deputy Director General, Department of Building,  
(Mr. JP Pradhan)**

**Member-Secretary**

The Subcontractor was BECA WORLEY INTERNATIONAL CONSULTANTS LTD. of New Zealand in conjunction with subconsultants who included :

Golder Associates Ltd., Canada  
SILT Consultants P. Ltd., Nepal  
TAEC Consult (P.) Ltd., Nepal  
Urban Regional Research, USA

Principal inputs to this standard came from :

Dr. AS Arya, University of Roorkee  
Mr. JK Bothara, TAEC  
Mr. YK Parajuli, TAEC  
Mr. AM Dixit, SILT  
Mr. AM Tuladhar, DoB, HMGN  
Dr. RD Sharpe, BECA (Team Leader)

Revisions and Updated to this code came from:

Mr. Purna P. Kadariya, DG, DUDBC  
Mr. Kishore Thapa, DDG, DUDBC  
Mr. Mani Ratna Tuladhar, Sr. Div. Engineer, DUDBC  
Mr. Jyoti Prasad Pradhan, Ex. DG, DOB  
Mr. Bhubaneswor Lal Shrestha, Ex. DDG, DOB  
Mr. Uttam Shrestha, Architect, Architects' Module Pvt. Ltd.  
Mr. Manohar Lal Rajbhandrai, Sr. Structural Engineer, MR Associates  
Mr. Amrit Man Tuladhar, Civil Engineer, DUDBC

## TABLE OF CONTENTS

Preface .....	i
<b>0 Foreword .....</b>	<b>v</b>
<b>0.1 Introduction .....</b>	<b>v</b>
<b>0.2 Objective .....</b>	<b>v</b>
<b>0.3 Limitations .....</b>	<b>v</b>
<b>0.4 Alternative Materials and Construction .....</b>	<b>v</b>
<b>0.5 What is a Pre-Engineered Building ? .....</b>	<b>vi</b>
<b>1 Scope .....</b>	<b>1</b>
<b>1.1 General .....</b>	<b>1</b>
<b>1.2 Related Standards .....</b>	<b>1</b>
<b>2 Interpretation .....</b>	<b>3</b>
<b>2.1 General .....</b>	<b>3</b>
<b>2.2 Terminology .....</b>	<b>3</b>
<b>2.3 Symbols .....</b>	<b>5</b>
<b>3 Selection and Investigation of Site .....</b>	<b>6</b>
<b>3.1 General .....</b>	<b>6</b>
<b>3.2 Use of Local Knowledge .....</b>	<b>6</b>
<b>3.3 Site Investigation Requirements .....</b>	<b>6</b>
<b>3.4 Allowable Bearing Pressure .....</b>	<b>6</b>
<b>4 The Building Structure .....</b>	<b>8</b>
<b>4.1 Description .....</b>	<b>8</b>
<b>4.2 Restrictions on the Structural Layout .....</b>	<b>8</b>
<b>5 Construction Materials .....</b>	<b>10</b>
<b>5.1 Concrete .....</b>	<b>10</b>
<b>5.2 Brickwork .....</b>	<b>10</b>
<b>5.3 Reinforcing Steel Bars .....</b>	<b>11</b>
<b>6 Design Procedure .....</b>	<b>11</b>
<b>6.1 Procedure Outline .....</b>	<b>11</b>
<b>6.2 Total Horizontal Seismic Base Shear .....</b>	<b>12</b>
<b>6.2.1 Design Seismic Coefficient .....</b>	<b>12</b>
<b>6.3 Distributing Total Horizontal Seismic Base Shear .....</b>	<b>13</b>

6.4	<b>Distribution of the Seismic Shear to the Individual Frames</b> .....	13
7	<b>Design of the Frames</b> .....	14
7.1	<b>Frames</b> .....	14
7.2	<b>Frame Analysis</b> .....	15
7.3	<b>Frame Design</b> .....	15
	7.3.1 <b>Basis of Recommendations</b> .....	15
	7.3.2 <b>Recommended Members Sizes and Minimum Reinforcement</b> .....	16
8	<b>Reinforcing Non-load Bearing Walls</b> .....	25
8.1	<b>Between Framing Columns</b> .....	25
	8.1.1 <b>Solid Walls</b> .....	25
	8.1.2 <b>Walls with Openings</b> .....	25
8.2	<b>Outside Framing Columns</b> .....	25
9	<b>Parapets</b> .....	29
9.1	<b>General</b> .....	29
9.2	<b>Flower Pots</b> .....	30

## **0. Foreword**

### **0.1 Introduction**

For the last 15 to 20 years there has been a proliferation of reinforced concrete (RC) framed buildings constructed in the urban and semi-urban areas of Nepal. Most of these buildings have been built on the advice of mid-level technicians and masons without any professional structural design input. These buildings have been found to be significantly vulnerable to a level of earthquake shaking that has a reasonable chance of happening in Nepal. Hence, these buildings, even though built with modern materials, could be a major cause of loss of life in future earthquakes. Upgrading the structural quality of future buildings of this type is essential in order to minimise the possible loss of life due to their structural failure.

### **0.2 Objective**

The main objective of these Mandatory Rules of Thumb (MRT) is to provide ready-to-use dimensions and details for various structural and non-structural elements for up to three-storey reinforced concrete (RC), framed, ordinary residential buildings commonly being built by owner-builders in Nepal. Their purpose is to replace the non-engineered construction presently adopted with pre-engineered construction so as to achieve the minimum seismic safety requirements specified by NBC 105 (a draft Nepal Seismic Design Standard).

This MRT is intended to cater primarily to the requirements of mid-level technicians (overseers and draughtspersons) who are not trained to undertake independently the structural design of buildings. However, civil engineers could also use this document for effective utilisation of their time by using the design procedures outlined here.

### **0.3 Limitations**

The requirements set forth in this standard shall be applicable only for buildings complying with the specified limitations. The intention is to achieve a minimum acceptable structural safety, even though it is always preferable to undertake specific investigations and design. Owners and builders are, however, encouraged to use the services of competent professional designers for better economy and tailor-made detailing. In such cases, the requirements stated here could be construed as advisory.

### **0.4 Alternative Materials and Construction**

The provisions of this Standard are not intended to prevent the use of alternative materials and methods of construction if such materials and methods are specifically prescribed by competent professional designers or other competent authorities equivalent to, or better than, those specified here.

## **0.5 What is a Pre-Engineered Building ?**

A pre-engineered building is one which uses the sizes and detailing of structural and non-structural elements, including the amounts of reinforcement, which have been pre-established using standard design procedures for a given condition. All buildings constructed by following the requirements of this MRT could, in future, be called pre-engineered buildings.



## 1 Scope

### 1.1 General

- 1.1.1** This MRT addresses the particular requirements of those RC-framed buildings which have become very common with owner-builders, who even undertake the construction of this type of buildings without employing professional designers. However, the users of this MRT are required to comply with certain restrictions with respect to building configuration, layout and overall height and size.
- 1.1.2** The MRT is intended for buildings of the regular column-beam type with reinforced concrete slabs for floors and the roof. The walls are assumed to be of burnt bricks, or hollow concrete or other rectangular blocks whose density will not exceed that of burnt bricks. Here, all the calculations are based on solid clay burnt bricks. These can be replaced by the above described blocks. The buildings have to comply with certain limitations listed in **Clause 4.1, 4.2**.
- 1.1.3** The MRT presents ready-to-use designs for all structural components, including detailing of structural as well as non-structural members for the specified building type.
- 1.1.4** Proportioning of structural components represented in MRT is for ordinary residential buildings located in most severe seismic zone (**Figure 1.1**).
- 1.1.5** The building could, of course, be alternatively designed using the usual design standards for engineered structures. The design procedures here are simplified in order both to save design time and to help owner-builders to adopt the recommended design and details so that they will achieve earthquake-resistant structures.

### 1.2 Related Standards

The requirements of this MRT are based on the following standards and documents. Compliance with this MRT will, therefore, result in compliance with these Standards :

- i) NBC 110 : (Draft Nepal Standard for Plain and Reinforced Concrete).
- ii) S.P. 16 –1980 : Design Aids for Reinforced Concrete to IS: 456-1978.
- iii) NBC 102/NBC 103 : (Draft Nepal Standard for Design Loads.;
- iv) NBC 105: (Draft Nepal Seismic Design Standard)
- v) IS : DOC : CED39 (5263) Guidelines for Ductile Detailing of Reinforced Concrete Structure subjected to Seismic Forces (under printing).

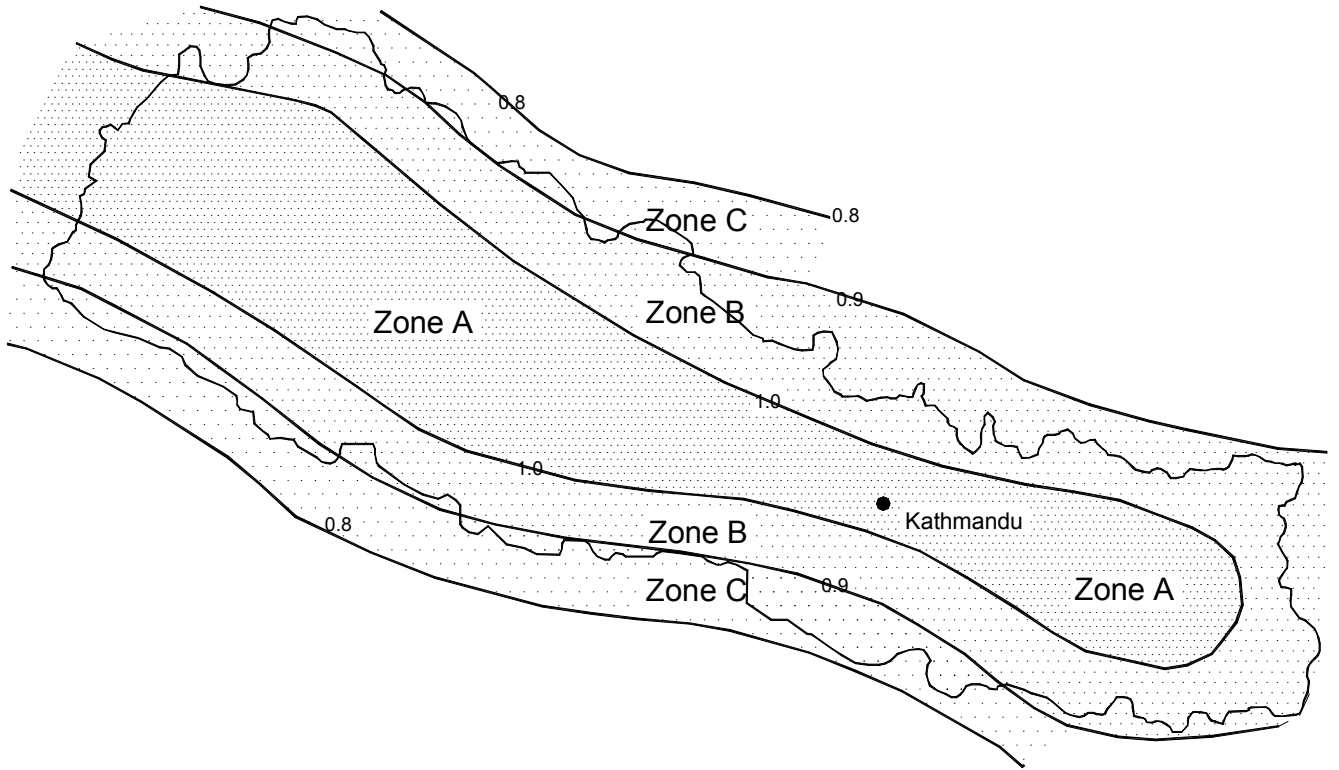

**Figure 1.1 : Seismic Zoning Map of Nepal for this MRT**

## 2 Interpretation

### 2.1 General

- 2.1.1** In this MRT, the word 'shall' indicates a requirement that is to be adopted in order to comply with the provision of this documents, while the word 'should' indicates recommended practice.
- 2.1.2** References to 'Code' indicate the draft standard for Seismic Design of Buildings in Nepal (NBC 105).
- 2.1.3** Words implying the singular only also include the plural and vice versa where the context requires this.

### 2.2 Terminology

In this Standard, unless inconsistent with the context, the following definitions shall apply :

**ADDITIONAL BARS** means the longitudinal bars that shall be provided in addition to regular bars at supports as top bars and at mid-span as bottom bars of a beam.

**CHAIR** means an element made of steel bar which is used to maintain the vertical distances between top and bottom bars in slabs.

**DEAD LOAD** means the weight of all permanent components of a building including walls, partitions, columns, floors, roofs, finishes and fixed plant and fittings that are an integral part of the structure.

**DESIGN** means use of rational computational or experimental methods in accordance with the established principles of structural mechanics.

**DIAPHRAGM** means a member composed of a web (such as a floor or roof slab), or a truss which distributes forces to the horizontal load-resisting system.

**DUCTILITY** means the ability of the building or member to undergo repeated and reversing inelastic deflection beyond the point of first yield while maintaining a substantial proportion of its initial maximum load-carrying capacity.

**FRAME** means a system composed of interconnected members functioning as a complete self-contained unit with or without the aid of horizontal diaphragms or floor-bracing systems.

**HORIZONTAL LOAD-RESISTING SYSTEM** means that part of the structural system to which the horizontal loads prescribed by this Standard are assigned.

**IMPORTANT BUILDINGS** means those buildings which either house facilities essential before and after a disaster (eg., hospitals, fire and police stations, communication centres, etc.), or which by their very purpose have to house large numbers of people at one time (eg., cinema halls, schools, convention centres, etc.), or which have special national and international importance (eg., palaces, etc.), or which house hazardous facilities (eg., toxic or explosive facilities, etc.).

**LANDSLIDE** means the downward and outward movement of slope-forming materials.

**LIQUEFACTION** means the phenomenon in which relatively loose, saturated sandy soils lose a large proportion of their strength under seismic shaking.

**LEVEL OF LOCAL RESTRAINT** means the level at which the ground motion of the earthquake is transmitted to the structure by interaction between the foundation materials and the foundation elements by friction and bearing.

**LIVE LOAD** means the load assumed or known to result from the occupancy or use of a building and includes the loads on floors, loads on roofs other than wind, loads on balustrades and loads from movable goods, machinery, and plant that are not an integral part of the structure and may be changed during the life of the building with a resultant change in floor or roof loading.

**LUMPED MASS** means the theoretical concentration of the mass of adjacent upper and lower half storeys at any floor level.

**MASONRY INFILL WALL** means any structural wall constructed in brick with cement sand mortar inside the frame and intended to carry horizontal load by equivalent compression strut action.

**NON-LOAD BEARING WALL** means any wall which is not intended to carry any significant external loads and which functions just as a cladding, partition wall or filler wall.

**ORDINARY BUILDING** means any building which is not an important building (eg., residential, general commercial, ordinary offices, etc.).

**REGULAR BARS** means the bars that shall run continually parallel to the walls of a beam to form a cage. The minimum number of regular bars in a beam is four.

**SHORT COLUMN** means a column whose effective length is reduced due to the sandwiching effect of a window sill wall spanning between two adjacent columns. The column effectively spans between lintel and sill level.

**SOFT STOREY** means a storey having a sudden decrease in its lateral stiffness compared to the adjacent upper storey.

**STOREY** means the space between two adjacent floors or platforms.

### 2.3 Symbols

$A$	Maximum horizontal length of building
$A_s$	Area of steel bar
$B$	Maximum horizontal width of building
$C_d$	Design seismic coefficient
$D$	Lateral stiffness of column
$f_{ck}$	Characteristic compressive strength of concrete
$F_i$	Horizontal seismic force applied at level $i$
$f_y$	Characteristic strength of steel
$h_i$	Height of the level $i$ above the lateral restraint imposed by ground
$K_1, K_2$	Plan length of structural wings
$K$	Steel grade Fe550 (high-strength, cold-worked)
$K_c$	Stiffness ratio of column (moment of inertial divided by its length)
$l$	Centre-to-centre span of beam
$M$	Steel grade Fe250 (mild steel)
$RC$	Reinforced cement concrete
$t_e$	Thickness at the edge of the pad foundation
$t_m$	Maximum thickness of the pad foundation
$T$	Steel grade Fe415 (high-strength, cold-worked)
$V$	Total horizontal seismic base shear
$V_{ij}$	Horizontal load carried by a column line $j$ at level $i$
$W_i$	Proportion of the $W_i$ at a particular level $i$
$W_i$	Total of the vertical dead loads and appropriate live loads above the level of lateral restraint provided by the ground
$\phi$	Diameter of steel bar

### 3 Selection and Investigation of Site

#### 3.1 General

This section sets out some of the requirements to be considered during site selection for the construction of buildings in order to minimise the risks to the buildings from primary geological as well as secondary seismic hazards such as fault rupture, landslides and liquefaction. A building shall not be constructed if the proposed site is :

- Water-logged
- A rock-falling area
- A landslide-prone area
- A subsidence and/or fill area
- A river bed or swamp area

#### 3.2 Use of Local Knowledge

It is a good practice during the construction of a building to examine the existing local knowledge and the history of the performance of existing buildings. This will assist in identifying whether there is any danger from inherent natural susceptibilities of the land to the processes of sliding, erosion, land subsidence and liquefaction during the past earthquakes or any other natural/geological processes likely to threaten the integrity of the building. The local practice of managing such hazards, if any, should be judged against the required level of acceptable risk.

#### 3.3 Site Investigation Requirements

Site exploration shall be carried out by digging test pits, two as a minimum, and more if the subsurface soil condition shows a significant variation in soil type.

Generally, the minimum depth of exploration for a building covered by this MRT shall be 2 m. In hilly areas, exploration up to the depth of sound bed-rock, if it lies shallower than 2 m, should suffice.

No exploration shall be required if the site is located on rock or on fluvial terraces (Tar) with boulder beds.

The soils encountered in the test pits should be classified as per **Table 3.1**.

#### 3.4 Allowable Bearing Pressure

The allowable bearing pressure that can be used is given in **Table 3.1** in conjunction with the visual classification of the subsurface soil type.

**TABLE 3.1 : FOUNDATION SOIL CLASSIFICATION AND SAFE BEARING CAPACITY**

	Type of Foundation Materials	Foundation Classification	Presumed Safe Bearing Capacity, kN/m <sup>2</sup>
1.	Rocks in different state of weathering, boulder bed, gravel, sandy gravel and sand-gravel mixture, dense or loose coarse to medium sand offering high resistance to penetration when excavated by tools, stiff to medium clay which is readily indented with a thumb nail.	Hard	$\geq 200$
2.	Fine sand and silt (dry lumps easily pulverised by the finger), moist clay and sand-clay mixture which can be indented with strong thumb pressure	Medium	$\geq 150$ and $< 200$
3.	Fine sand, loose and dry; soft clay indented with moderate thumb pressure	Soft	$\geq 100$ and $< 150$
4.	Very soft clay which can be penetrated several centimetres with the thumb, wet clays	Weak	$\geq 50$ and $< 100$

## 4 The Building Structure

### 4.1 Description

The structure is a reinforced concrete frame without any contribution of masonry infill walls in resisting the vertical or seismic loads. The frame shall comply with **Clause 4.1, 4.2** and be designed to resist earthquake forces as a bare frame.

### 4.2 Restrictions on the Structural Layout

For a structure to be built using this MRT, it shall comply with the restrictions set out below. If the structure does not comply, it must be designed in accordance with the Standards referred to in **Clause 1.2** or latest appropriate standard.

The restrictions are :

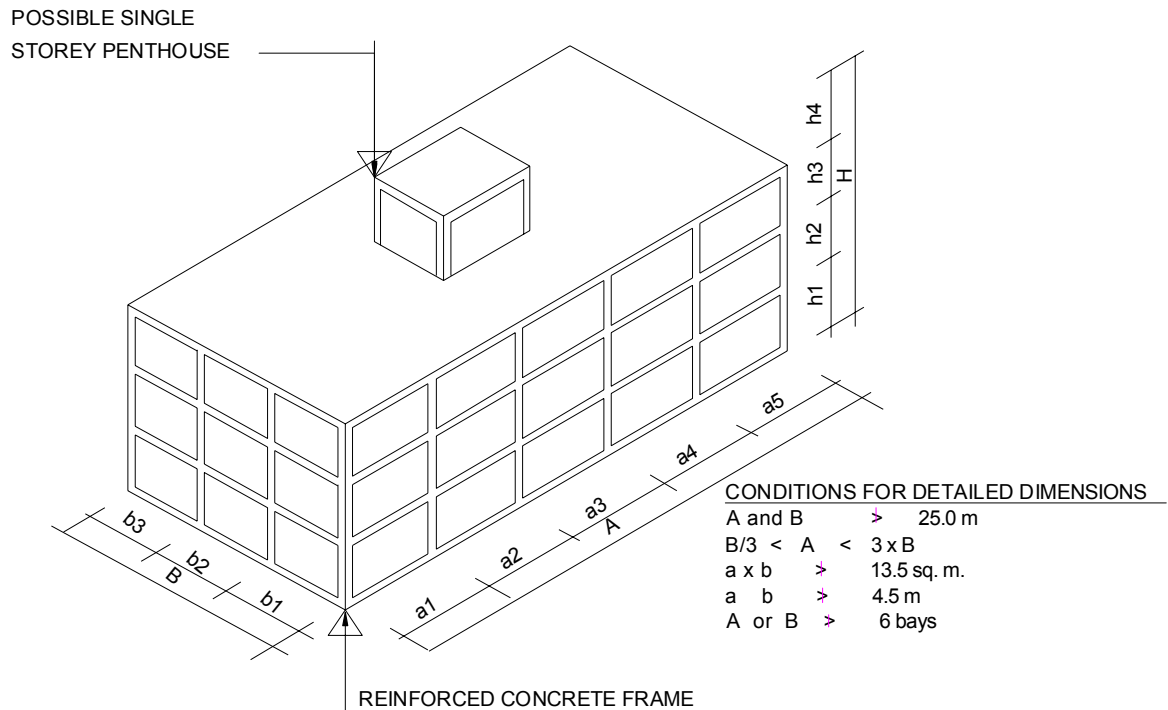

- (a) Neither  $A$  nor  $B$  shall exceed 6 bays in length nor 25 metres. Each bay shall not exceed 4.5 m, as shown in **Figure 4.1**.

[Note: 1. Openings can be provided as per functional/architectural requirements.

2. Foundation is not shown.]

**Figure 4.1 : Reinforced Concrete Frame**



- (b)  $A$  shall be not greater than  $3 B$  nor less than  $B/3$ .
- (c) Neither  $H/A$  nor  $H/B$  shall exceed 3.
- (d) The area of a slab panel shall not be more than 13.5 square metres.
- (e) The maximum height of the structure is 11 m or 3 storeys, whichever is less, from the level of lateral restraint. Within an 11 m height, there may be an additional storey of smaller plan area. The area of this shall not exceed 25 % of the area of a typical floor, as given in **Figure 4.1**. If this limit is exceeded, it shall be considered as an additional storey and not permitted.
- (f) The length of wings on the structure shall be restricted such that  $K_1$  and  $K_2$  shall be less than the lesser of  $0.25 A$  or  $0.25 B$ . The width of the wings shall be restricted as shown in **Figure 4.2**. The plan shape of the building excluding wings shall be rectangular.
- (g) All columns resisting lateral load shall be vertical and shall continue on the same centreline down to foundation level. The top storey may, however, be smaller or have a different geometry subject to the provisions of subparagraph (e) above.

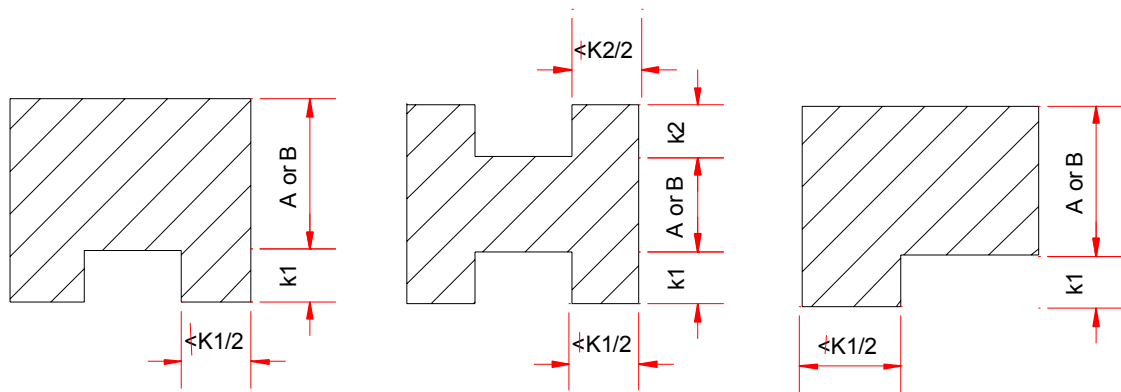

$K_1, K_2 < 0.25 A$  or  $0.25 B$ , which ever is less.

**Figure 4.2 : Restrictions on Plan Projection**

- (h) No walls except a parapet wall shall be built on a cantilevered slab. Such walls shall be constructed only if the cantilevered slab is framed with beams.
- (i) The foundation shall be at a uniform level.
- (j) Buildings shall not have a soft storey.

## 5 Construction Materials

### 5.1 Concrete

The concrete to be used in footings, columns, beams and slabs, etc., shall have a minimum crushing strength of 15 N/mm<sup>2</sup> at 28 days for a 150 mm cube.

Cement: Cement shall be as fresh as possible. Any cement stored for more than two months from the date of receipt from the factory should either be avoided or tested and used only if the test results are found to be satisfactory. Any cement which has deteriorated or hardened shall not be used. All cement used shall be Ordinary Portland Cement meeting the requirements of NS : 049-2041. It is advisable to use cement which has obtained the NS mark if independent tests are not carried out.

Coarse Aggregates: Coarse aggregates shall consist of crushed or broken stone and shall be hard, strong, dense, durable, clean, of proper grading and free from any coating likely to prevent the adhesion of mortar. The aggregate shall be generally angular in shape. As far as possible, flaky, elongated pieces shall be avoided. The aggregate shall conform to the requirements of IS : 383-1970 and IS : 515-1959.

The coarse aggregates shall be of following sizes :

- (a) Normal cement concrete with a thickness of 100 mm and above - graded from 20 mm downwards
- (b) Cement concrete from 40 mm to 100 mm thick - graded from 12 mm downwards

Sand: Sand shall consist of a silicious material having hard strong, durable, uncoated particles. It shall be free from undesirable amounts of dust lumps, soft or flaky particles, shale, salts, organic matter, loam, mica or other deleterious substances. In no case shall the total of all the undesirable substances exceed five percent by weight.

[Note : Refer to the construction guidelines ]

### 5.2 Brickwork

The brick masonry shall be built with the usually specified care regarding pre-soaking of bricks in water, level bedding of planes fully covered with mortar, vertical joints broken from course to course and their filling with mortar fully.

Bricks : The bricks shall be of a standard rectangular shape, burnt red, hand-formed or machine-made, and of crushing strength not less than 3.5 N/mm<sup>2</sup>. The higher the density and the strength, the better they will be. The standard brick size of 240 x 115 x 57 mm with 10 mm thick horizontal and vertical mortar joints is preferable. Tolerances of -10 mm on length, -5 mm on width and  $\pm 3$  mm on thickness shall be acceptable for the purpose of thick walls in this MRT.

Wall Thickness : A minimum thickness of one half-brick and a maximum thickness of one brick shall be used.

Mortar : Cement-sand mixes of 1:6 and 1:4 shall be adopted for one-brick and a half-brick thick walls, respectively. The addition to the mortars of small quantities of freshly hydrated lime in a ratio of  $\frac{1}{4}$  to  $\frac{1}{2}$  of the cement will greatly increase their plasticity without reducing their strength. Hence, the addition of lime within these limits is encouraged.

Plaster : All plasters should have a cement-sand mix not leaner than 1:6. They shall have a minimum 28 days cube crushing strength of 3 N/mm<sup>2</sup>.

### 5.3 Reinforcing Steel Bars

Reinforcing steel shall be clean and free of loose mill-scale, dust, loose rust and coats of paints, oil, grease or other coatings, which may impair or reduce bond. It shall conform to the following NS or IS specifications.

Mild steel bars conforming to NS:84-2042 or IS: 432 (Part I) - 1996 with  $f_y = 250$  N/mm<sup>2</sup>, or high-strength deformed bars conforming to IS : 1139-1966 or NS :191-2046 with  $f_y = 415$  N/mm<sup>2</sup> or  $f_y=550$  N/mm<sup>2</sup> shall be used for reinforcing all masonry and concrete.

- [Note: 1. In the presentation of this MRT,  $f_y = 415$  N/mm<sup>2</sup> steel is assumed for main bars in beams and columns. For using any other steel with lower values of  $f_y$ , the steel area shall be correspondingly increased.
2. High-strength steel bars having  $f_y= 550$  N/mm<sup>2</sup> may only be used as reinforcement in slabs.
3. 7  $\phi$  bars steel grade Fe550 can be replaced by 8  $\phi$  bars of steel grade Fe415. Similarly, 5  $\phi$  bars of steel grade Fe550 can be replaced by 6  $\phi$  bars of steel grade Fe250.

## 6 Design Procedure

### 6.1 Procedure Outline

The simplified design procedure comprises the following stages:

- (a) Conforming that the building plan meets the structural layout restrictions (**Clause 4.1, 4.2**).
- (b) Calculate total horizontal seismic base shear on the building (**Clause ?**).
- (c) Distribute total horizontal seismic base shear up the height of the building (**Clause 6.3**).

- (d) Distribute the total horizontal seismic load to the individual load resisting elements (**Clause 6.4**).
- (e) Design and detail the structural elements :
  - i) The frame (**Clauses 7.1 – 7.3**)
  - ii) Recommendation for minimum sizes and reinforcement (**Clause 7.3.2**)
- (f) Reinforcing non load-bearing walls (**Section 8**)
- (g) Reinforcing of parapets (**Section 9**)

## 6.2 Total Horizontal Seismic Base Shear

The structure shall be designed to withstand a total horizontal seismic base shear,  $V$ , calculated in accordance with the formula :

$$V = C_d \times W_t \quad (6.1)$$

where,

$W_t$  is the combination of the total vertical dead load and 25 % of the live loads above the level of lateral restraint provided by the ground.

### 6.2.1 Design Seismic Coefficient<sup>1</sup>

The design seismic coefficients,  $C_d$ , for the design of frames without masonry in-fills in the zones shown in **Figure 1.1** are :

Zone A = 0.080, Zone B = 0.072, Zone C = 0.064

Where a building location lies close to a zone boundary so that its particular zone is uncertain, then the building shall be assumed to fall in the zone requiring the higher value of basic seismic coefficient.

---

<sup>1</sup> *Seismic coefficients are in accordance with NBC 105 for ductile frames of normal importance on a medium grade of soil.*

### 6.3 Distributing Total Horizontal Seismic Base Shear

The total horizontal base shear,  $V$ , shall be distributed up the height of the building in accordance with the formula (refer to **Figure 6.1**) :

$$F_i = V \left( \frac{W_i h_i}{\sum_i W_i h_i} \right) \quad (6-2)$$

where,

$F_i$  is the load applied at the level designated as  $i$ .

$W_i$  is the proportion of  $W_i$  at  $i^{\text{th}}$  level.

$h_i$  is the height of level  $i$  above of level of lateral restraint imposed by the ground.

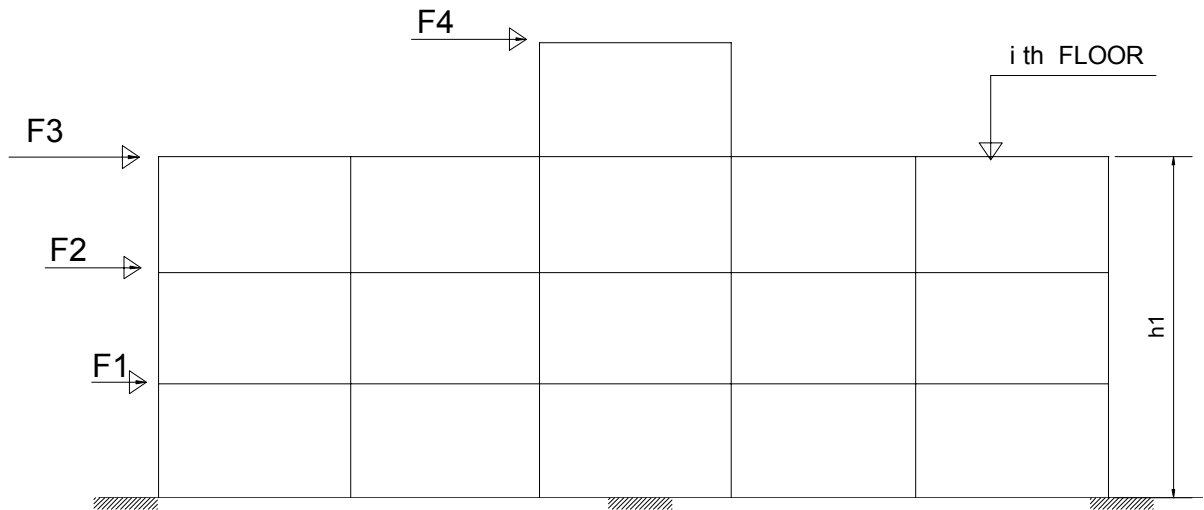

**Figure 6.1 : Floor Level Lateral Forces**

### 6.4 Distribution of the Seismic Shear to the Individual Frames

In a particular storey  $i$ , the shear force,  $V_{ij}$ , resisted by a column line  $j$  shall be determined from the formula :

$$F_{ij} = \left( \frac{D_{ij}}{\sum_j D_{ij}} \right) \sum_i^{Roof} F_i \quad (6-3)$$

where :

Roof :

$\sum_i F_i$  is the sum of floor loads above the particular storey  $i$ .

$D_{ij}$  is the effective lateral stiffness of the particular column line  $j$  in storey  $i$ .

$\sum_j D_{ij}$  is the sum of the effective lateral stiffness of all the columns in particular storey  $i$ .

Lateral stiffness of an individual column is given by :

$$D = 12 \left( \frac{EI_e}{h^3} \right) \quad (6-4)$$

where :

$E$  Young's modulus of column concrete.

$I_c$  Moment of inertia of column in the plane of consideration.

$h$  Height of the column

## 7 Design of the Frames

### 7.1 Frames

All frames shall be designed :

- (a) to support the applied vertical gravity loads (including the weight of the walls) without assistance from the walls, and
- (b) for seismic condition using forces as per **Clause 6.1**.

## 7.2 Frame Analysis

Frame-by-frame analysis may be carried out using any of the hand calculation methods (eg, Portal method, Sutherland-Bowman method, Arya's Modified Frame method, or Muto's D-value method), or by using a computer analysis, to determine the forces and moments in frame members.

## 7.3 Frame Design

The members and joints shall then be designed in accordance with standard practice and shall be detailed to achieve ductile deformations under severe earthquakes.

The recommendations for member sizes and minimum reinforcement in all components are shown in **Figures 7.1 to 7.4**. The reinforcement shall also comply with the applicable sections.

### 7.3.1 Basis of Recommendations

The recommended sizes of members and the reinforcement are based on sample calculations using the following data :

Building Occupancy	:	Residential
Column Plan	:	4.5 x 3.0 m bays
Number of Storeys	:	three
Storey Height		
1st storey	:	3.2 m floor to floor
Upper storey	:	2.8 m floor to floor
Wall Thicknesses	:	up to 115 mm thick brick wall or equivalent for all internal walls and up to 230 mm thick brick wall or equivalent for all external walls
Cantilever Floor Projection	:	1.0 m (from centre-line of beam)
Concrete mix	:	M15 (15 N/mm <sup>2</sup> cube crushing strength at 28 days) minimum
Reinforcement	:	Fe250 (minimum yield strength = 250 N/mm <sup>2</sup> ), Fe415 (minimum yield strength = 415 N/mm <sup>2</sup> ), Fe550 (minimum yield strength = 550 N/mm <sup>2</sup> )

Mortar	:	Minimum 1:4 cement-sand mortar for half-brick thick wall and 1:6 cement-sand mortar for one-brick thick
Bricks	:	Minimum crushing strength 3.5 N/mm <sup>2</sup>
Seismic Coefficient	:	$C_d = 0.08$ (for infill frame on medium grade of soil)

### 7.3.2 Recommended Members Sizes and Minimum Reinforcement

#### Slab

##### **Roof and Floors**

Thickness	:	100 mm
Steel	:	T08 or K07 and M06 or K4.75 bars as shown in <b>Figure 7.1</b> .

#### Beams

##### **Roof and floors (both directions)**

Width	:	230 or 240 mm
Depth	:	325 mm overall including slab

##### **Plinth beam (both directions)**

Width	:	230 mm or 240 mm
depth	:	200 mm overall

##### **Longitudinal Steel**

The top and bottom steel reinforcement bars are given in **Table 7.1** for different spans. The placing of steel shall meet the requirements specified in **Figure 7.2**.



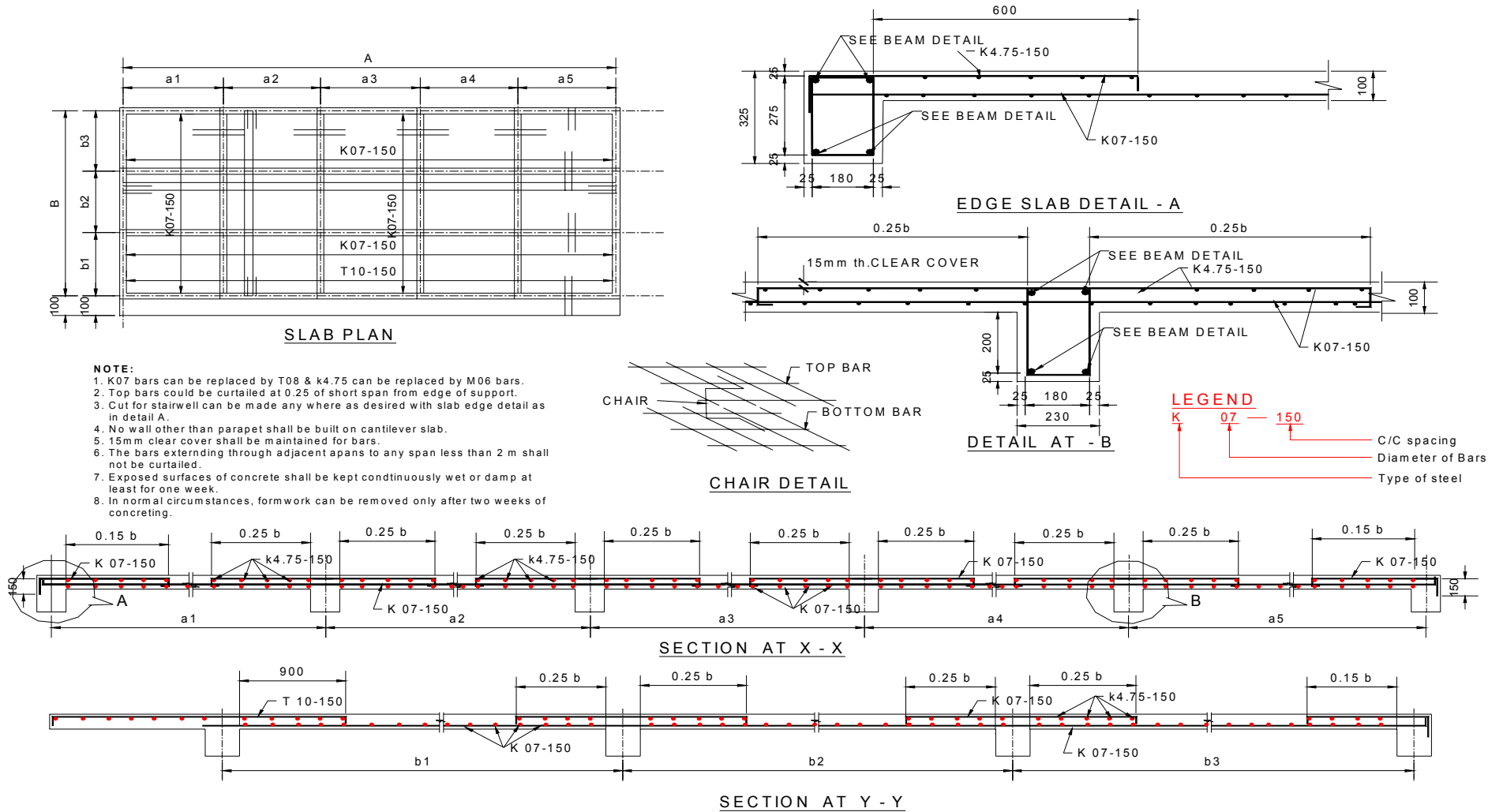

Figure 7.1 : Slab Reinforcement Details

**TABLE 7.1 : LONGITUDINAL STEEL IN BEAMS**

Span	4.5 ≥ l > 4.0				4.0 ≥ l > 3.5				3.5 ≥ l > 3.0				l ≤ 3.0			
Bar type/ Level	Regular		Additional		Regular		Additional		Regular		Additional		Regular		Additional	
	Top	Bot.	Top	Bot.	Top	Bot.	Top	Bot.	Top	Bot.	Top	Bot.	Top	Bot.	Top	Bot.
Roof	2T12	2T12	1T12	1T12	2T12	2T12	1T12	1T10	2T12	2T12	1T10	1T10	2T12	2T12	1T10	-
II	2T16	2T16	1T16	1T12	2T16	2T16	1T12	1T10	2T12	2T12	2T12	1T16	2T12	2T12	1T16	1T12
I	2T16	2T16	3T12	1T16	2T16	2T16	2T12	1T16	2T16	2T16	1T16	1T16	2T16	2T16	1T12	1T12
Plinth	2T12	2T12	-	-	2T12	2T12	-	-	2T12	2T12	-	-	2T12	2T12	-	-

- [Note: 1. 1T12 stands for 1 number of 12 mm diameter of steel grade Fe415 bar.  
2. Additional top bars coming from adjacent span shall not be curtailed if the span under question is less than 2 m.  
3. In case of two adjacent beams of different span, top bars for longer span shall govern.]

**Transverse Stirrups :** The transverse stirrups are calculated and presented in **Table 7.2** for different spans. The placing of transverse stirrups shall meet the requirements set out in **Figure 7.2**. The depth of the foundation shall not be less than 1.2 m.

**TABLE 7.2 : TRANSVERSE STIRRUPS IN BEAMS  
(All stirrups are 2-legged)**

Level\Span	4.5 ≥ l > 3.5	3.5 ≥ l > 3.0	Remarks
Roof	End 600 mm - M06 @ 100	End 600 mm - M06 @ 100	In the Remaining Length of All Beams Use M06 @ 150
II	End 900 mm - M06 @ 100	End 600 mm - M06 @ 100	
I	End 0.3 l - M06 @ 80	End 0.3 l - M06 @ 100	
Plinth	M06 @ 100	M06 @ 100	

- [Note: 1. M06 @ 100 stands for 6 mm φ Fe250 (mild steel) two-legged stirrups at a spacing of 100 mm c/c.]

### Columns

#### **Size and Longitudinal Steel**

Gross sections of column and longitudinal steel are calculated and presented in **Table 7.3**.

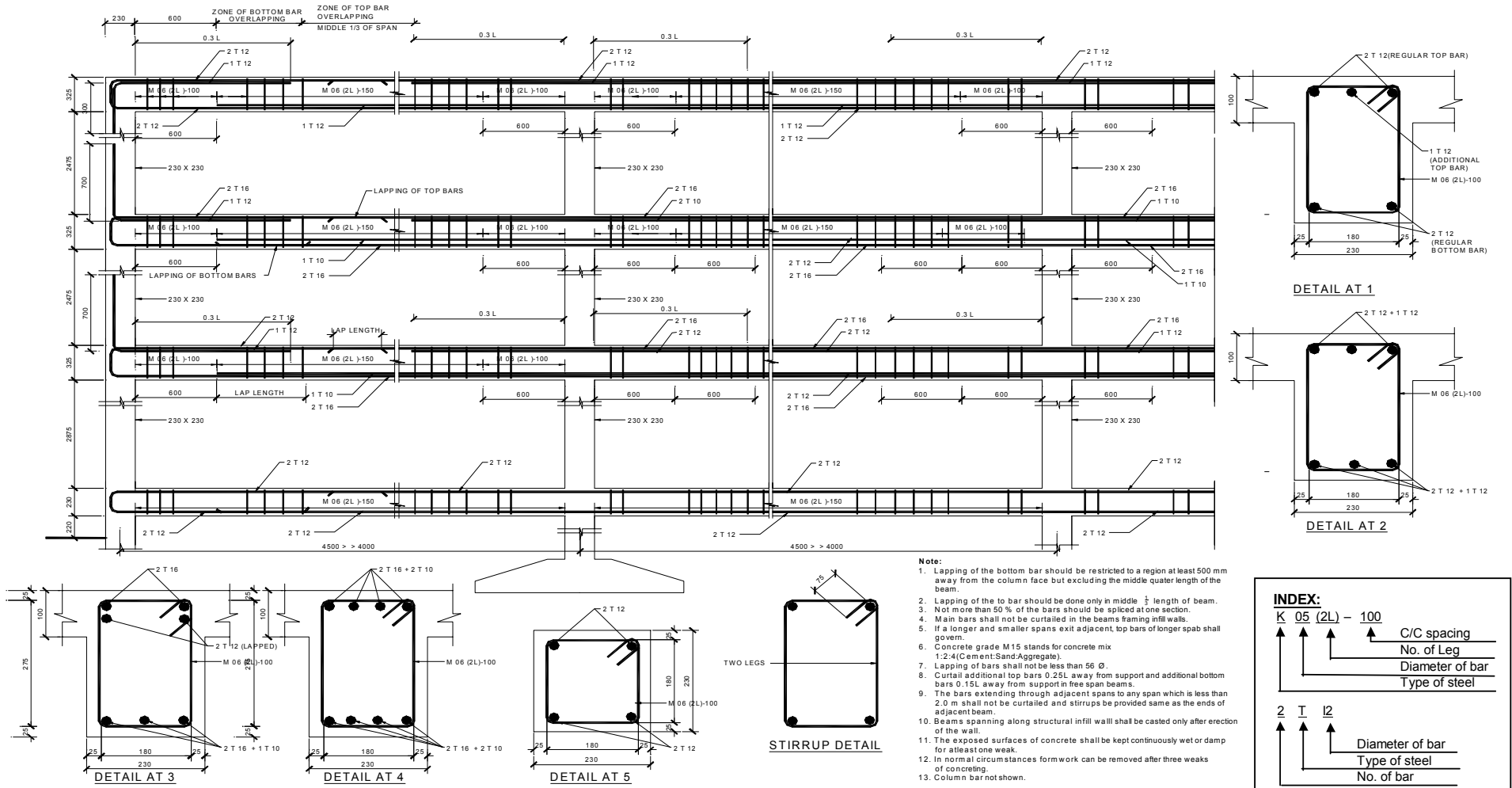

Figure 7.2 : Beam Details

**TABLE 7.3 : COLUMN SIZES AND LONGITUDINAL STEEL**

Storey	Corner Column		Face Column		Interior Column	
	Size	Reinf. ( $A_s$ )	Size	Reinf. ( $A_s$ )	Size	Reinf. ( $A_s$ )
III*	230 x 230	4T16	230 x 230	4T12	230 x 230	4T12
II	230 x 230	4T16	230 x 230	4T16	230 x 230	8T12
I	270 x 270	4T16	270 x 270	4T16	270 x 270	8T12

\* and Penthouse.

[Note: 1. 4T16 stands for 4 number of 16 mm  $\phi$  Fe415 steel bars].

### Transverse Stirrups

The transverse stirrup ties in all columns shall be :

Ends of columns for 600 mm length - T 08 @ 100  
 Remaining height - T 06 @ 125

[Note: 1. Continue the column stirrups as specified to the ends if column stands adjacent to a window or such opening to take care of the short-column effect.]

2. T08 @ 100 stands for 8 mm  $\phi$  steel grade Fe415 stirrups at the spacing of 100 mm c/c. All stirrups are of a closed type.]

Details of columns shall be as specified in **Figure 7.3**.

### Pad Foundations

Sizes and reinforcement in pad foundations for different soil types and loadings are presented in **Tables 7.4a to 7.4d**. All foundations are individual tapering-type pads. Details of foundations shall be as given in **Figure 7.4**.

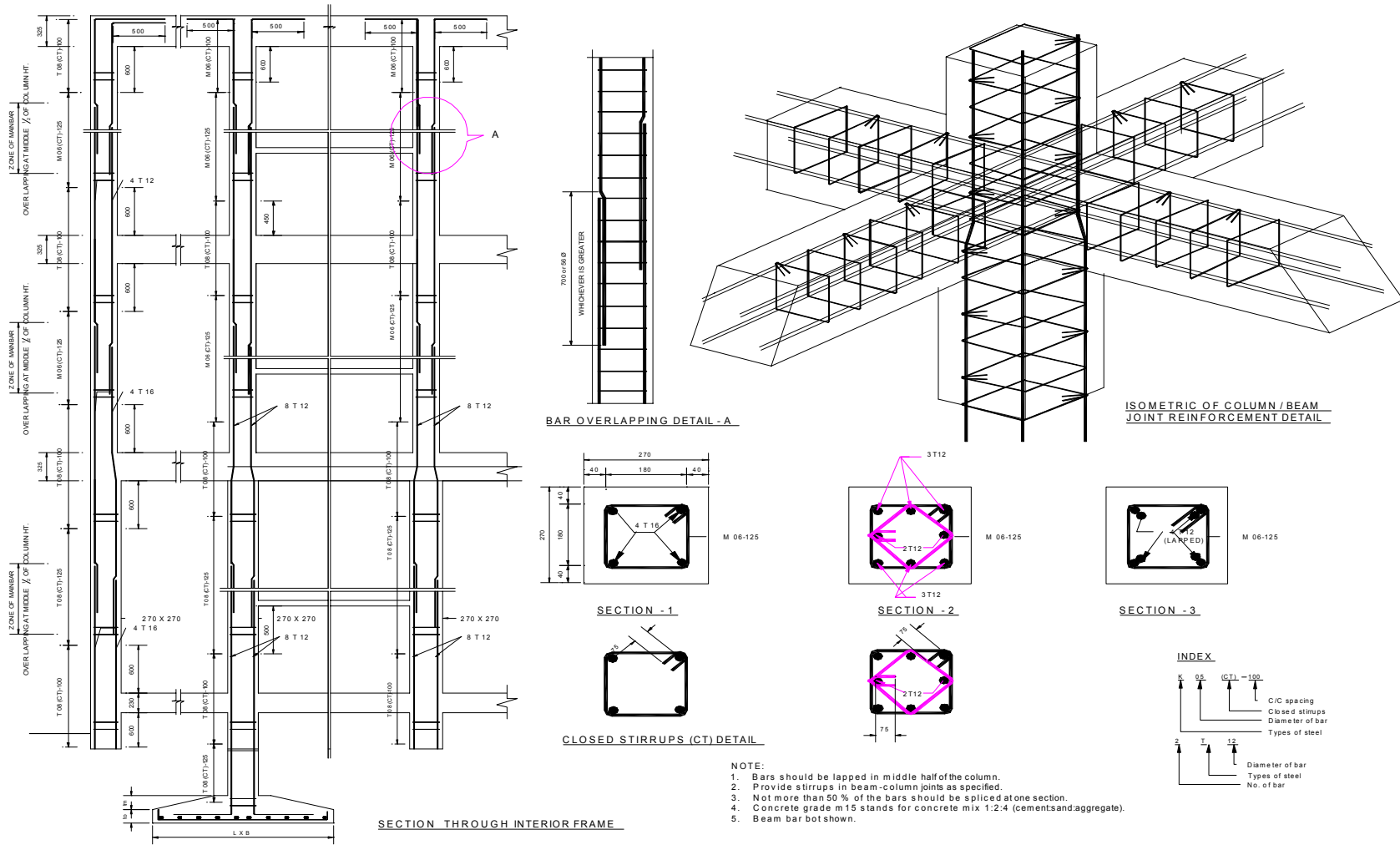

Figure 7.3 : Column Detail



**TABLE 7.4B : PAD FOUNDATION SIZE FOR SOFT SOILS**  
(safe bearing capacity = 100 kN/m<sup>2</sup>)

Column Type	Column Location	Foundation Plan <i>L x B</i> (m)	Thickness at Edges <i>t<sub>e</sub></i> (mm)	Maximum Thickness <i>t<sub>m</sub></i> (mm)	Reinf. Each Way <i>A<sub>s</sub></i>
	Cantilever Side				
Corner	No	1.1 x 1.1	150	325	5T10
Corner	Yes	1.2 x 1.2	150	325	6T10
Face	No	1.4 x 1.4	150	400	6T12
Face	-	1.6 x 1.6	150	425	7T12
Face	Yes	1.6 x 1.6	150	425	7T12
Interior	-	1.8 x 1.8	200	500	9T12

**TABLE 7.4C : PAD FOUNDATION SIZE FOR MEDIUM SOILS**  
(Safe Bearing Capacity = 150 kN/m<sup>2</sup>)

Column Type	Column Location	Foundation Plan <i>L x B</i> (m)	Thickness at Edge <i>t<sub>e</sub></i> (mm)	Maximum Thickness <i>t<sub>m</sub></i> (mm)	Reinforcement Each Way <i>A<sub>s</sub></i>
	Cantilever Side				
Corner	no	1.0 x 1.0	150	325	5T10
Corner	yes	1.0 x 1.0	150	325	6T10
Face	no	1.2 x 1.2	175	425	8T10
Face	yes	1.3 x 1.3	175	450	7T12
Interior	-	1.6 x 1.6	225	525	8T12

**TABLE 7.4D : PAD FOUNDATION SIZE FOR HARD SOILS**  
(safe bearing capacity = 200 kN/m<sup>2</sup>)

Column Type	Column Location	Foundation Plan $L \times B$ (m)	Thickness at Edges $t_e$ (mm)	Maximum Thickness $t_m$ (mm)	Reinf. each way $A_s$
	Cantilever Side				
Corner	No	0.8 x 0.8	150	350	5T10
Corner	Yes	0.9 x 0.9	150	350	5T10
Face	No	1.0 x 1.0	200	450	7T10
Face	-	1.1 x 1.1	200	450	7T10
Face	Yes	1.1 x 1.1	200	450	7T10
Interior	-	1.3 x 1.3	250	550	7T12

Toe Wall : All plinth beams shall be constructed on a toe wall below them as given in **Figure 7.5**.

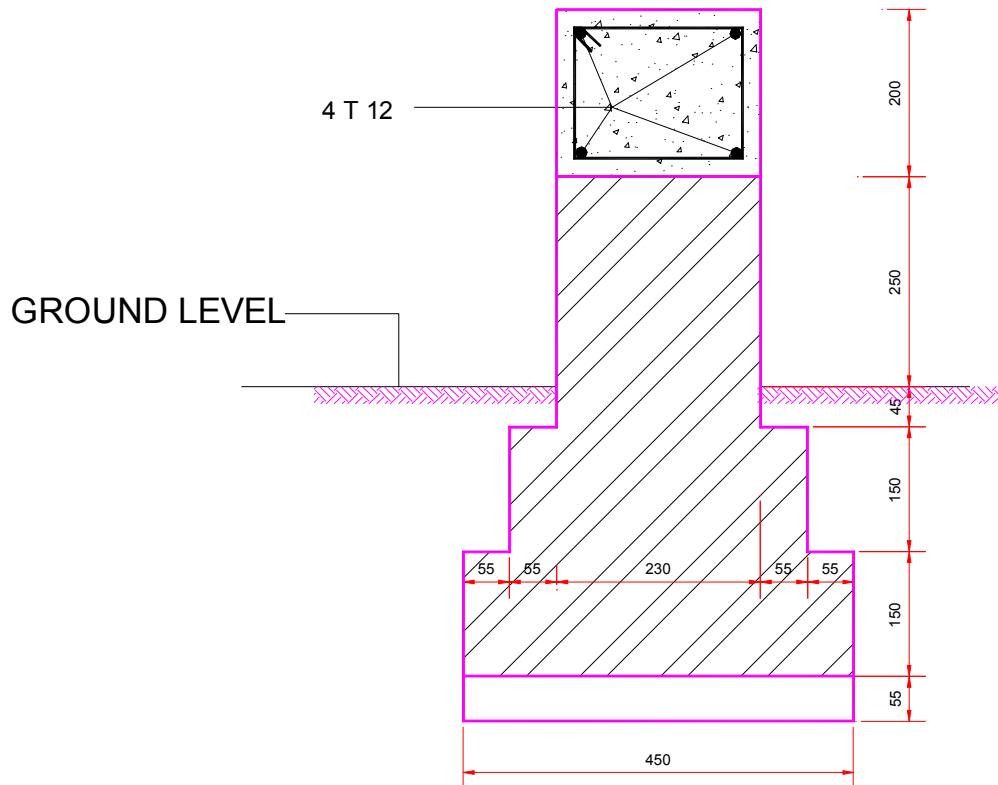

**Figure 7.5 : Toe Wall Details**



## 8 Reinforcing Non-load Bearing Walls

### 8.1 Between Framing Columns

#### 8.1.1 Solid Walls

To prevent walls from falling out, these shall be provided with horizontal reinforced concrete (RC) bands through the wall at about one-third and two-thirds of their height above the floor in each storey.

The width of the band should be equal to the wall thickness and its thickness equal to that of the masonry unit, or 75 mm, whichever is larger. Reinforcement details shall be as given in **Figure 8.1**.

#### Reinforcement :

- (a) Longitudinal - two bars 8 mm  $\phi$  (Fe415) anchored fully in the RC column abutting the wall.
- (b) Transverse - links 6 mm  $\phi$  (Fe250) stirrups at every 150 mm.

#### 8.1.2 Walls with Openings

Provide an horizontal RC band through the wall at the lintel level of doors and windows and at window sill level in each storey as given in **Clause 8.1.1**.

Details of the arrangement are given in **Figure 8.2**.

### 8.2 Outside Framing Columns

A horizontal RC band shall be provided through all walls - one at window-sill level and the other at lintel-level. All details shall be the same as in **Clause ?**.

The reinforcement of bands shall be taken through the cross-walls into the RC columns as detailed in **Figure 8.3**.

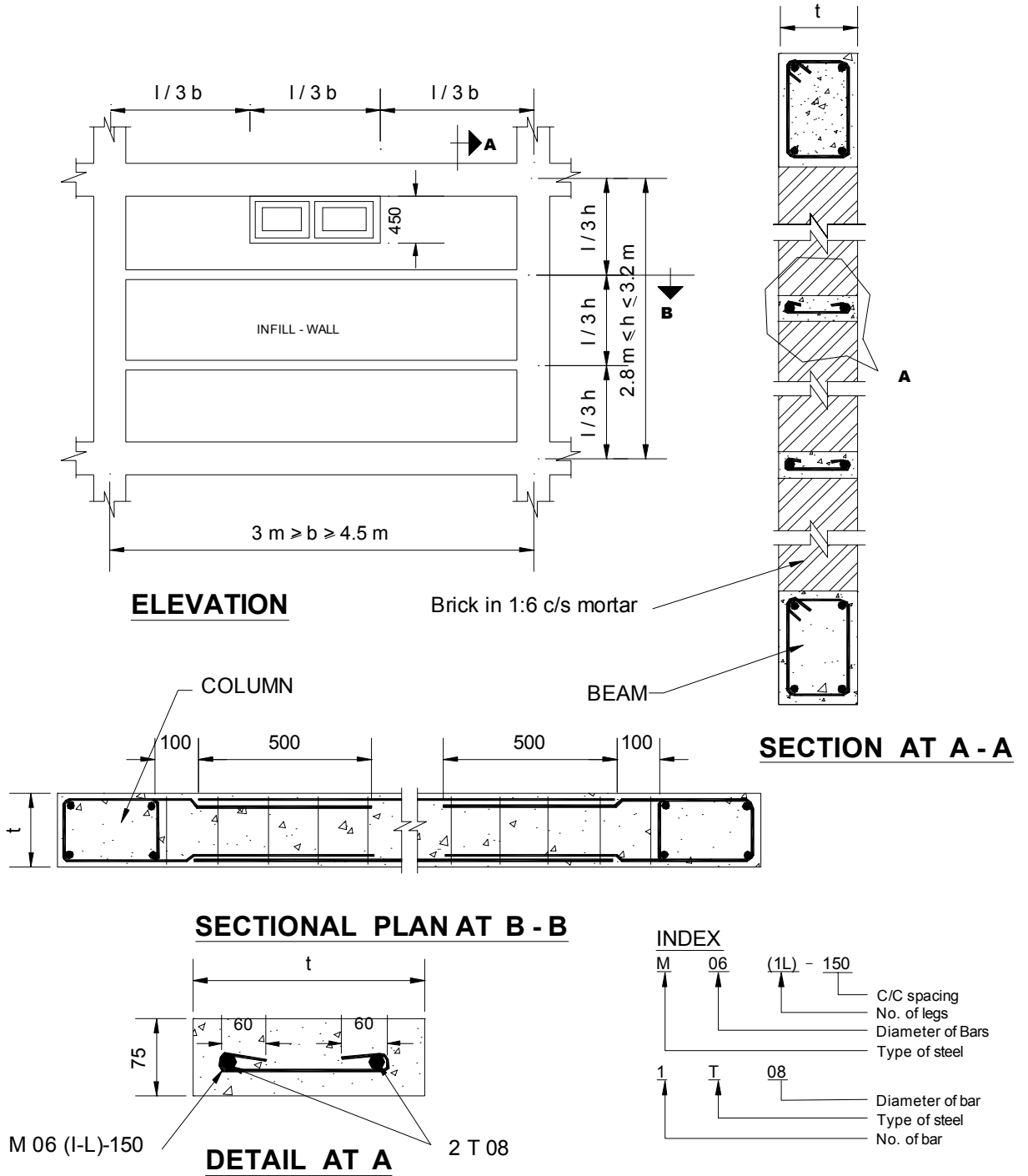

Figure 8.1 : Tie-Band Detail of Solid Walls

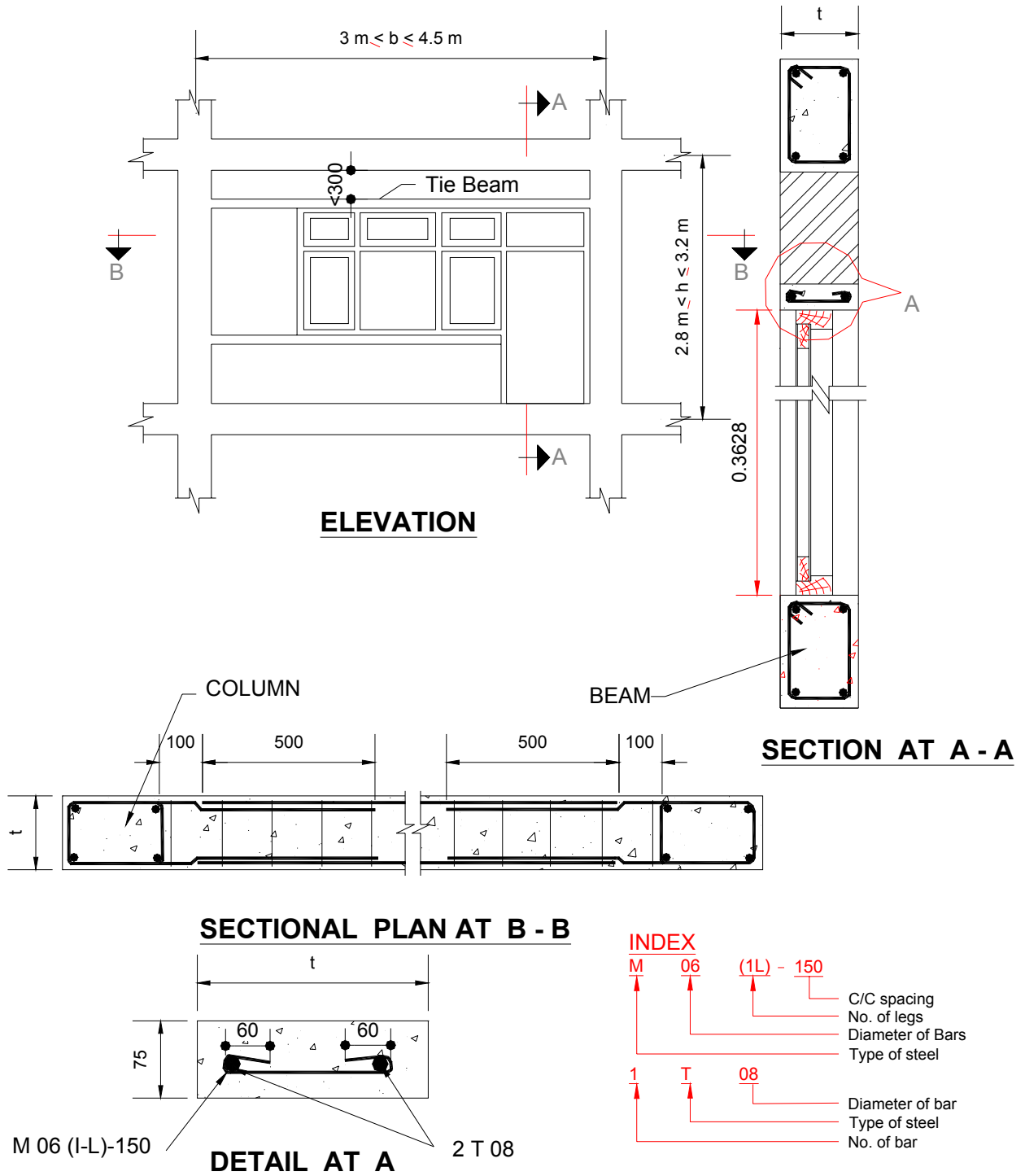

Figure 8.2 : Tie Up and Detail of Non-Structural Wall

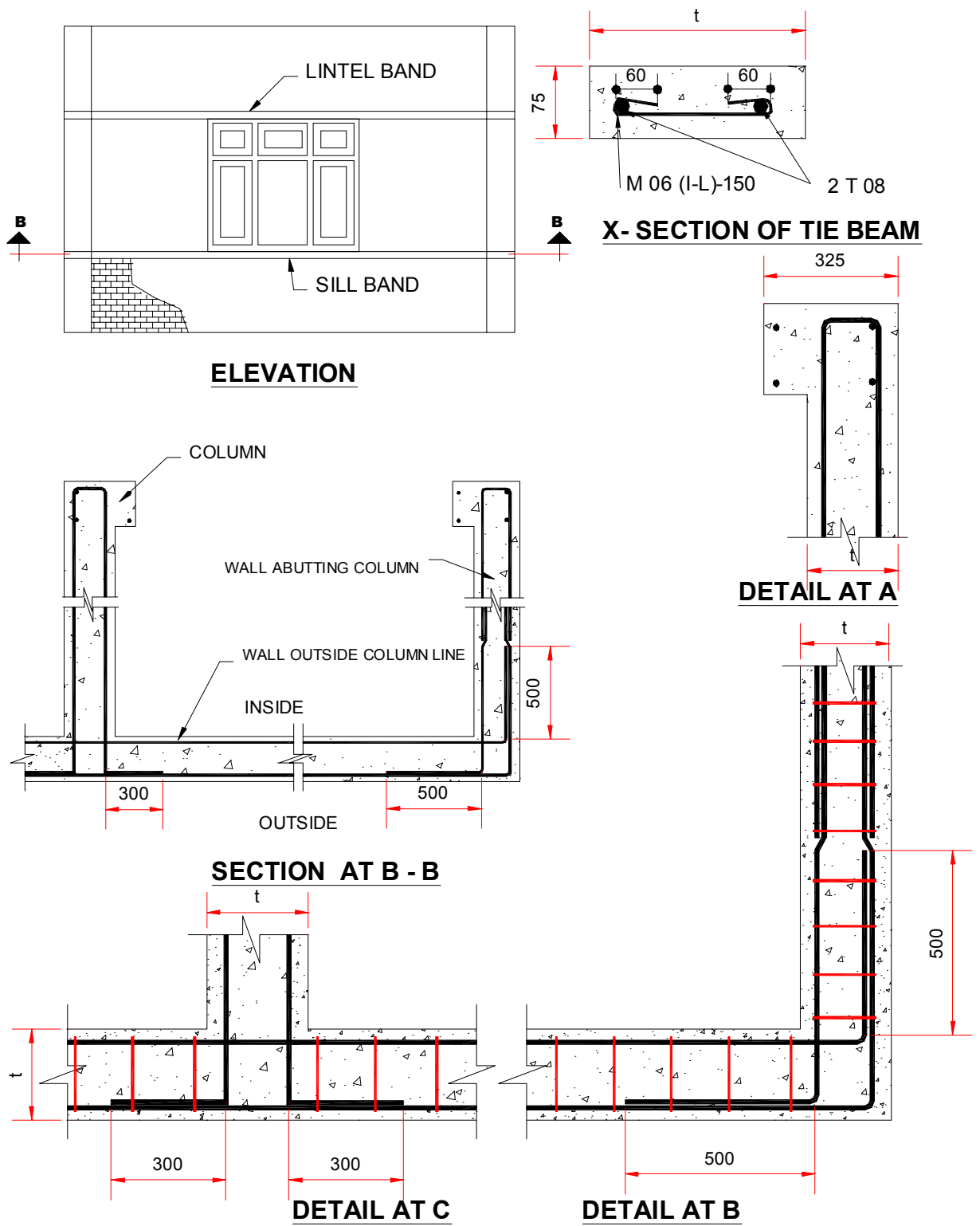
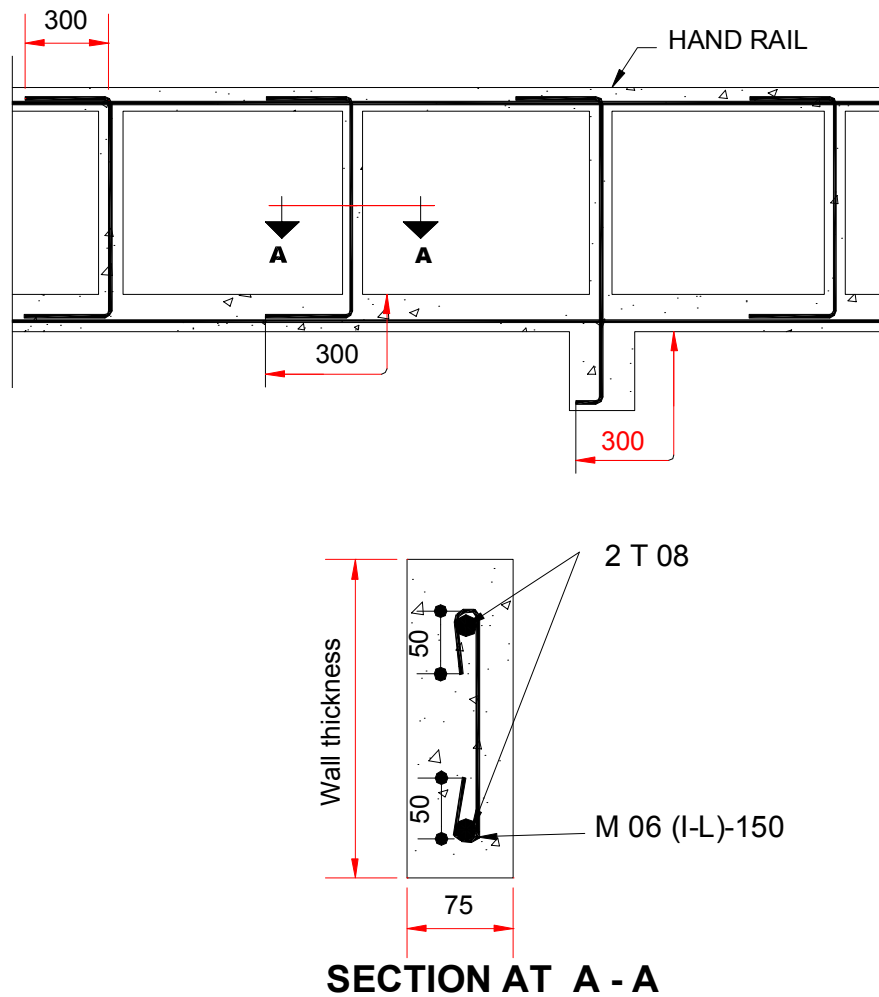

Figure 8.3 : Wall Outside the Frame

## 9 Parapets

### 9.1 General

Parapets above roofs and at the edges of the balconies should not be taller than one metre. They should either be constructed in reinforced concrete or be reinforced with vertical RC elements spaced not more than 1.5 m apart. The section of the vertical RC post may be kept to  $b \times 75$  mm, where  $b$  is the thickness of the parapet. Such RC elements should be reinforced with two vertical bars of 8 mm diameter steel (grade Fe415) with transverse links 6 mm  $\phi$  diameter steel (grade Fe250) @ 150 mm centres. The vertical reinforcement shall be tied in the steel of the slab or beam below with a minimum embedment of 300 mm. Also, a handrail should be provided at the top with a section size and reinforcing as explained in **Clause 8.1.1**. For details, refer to **Figure 9.1**.



**Figure 9.1 : Parapet Wall Tie-Up Details**

## 9.2 Flower Pots

Flower pots should not normally be placed on parapets. However, if it is desired that they be placed there, they shall be adequately wired and held to the parapet through pre-fixed steel hooks/anchors so that they will not be dislodged in severe earthquake shaking.